



IMPACT • ACCESS • INCLUSION

The Classical Preisach Model of Hysteresis

Yifan Yuan

Group meeting

08/14/2020



The phenomenon of hysteresis

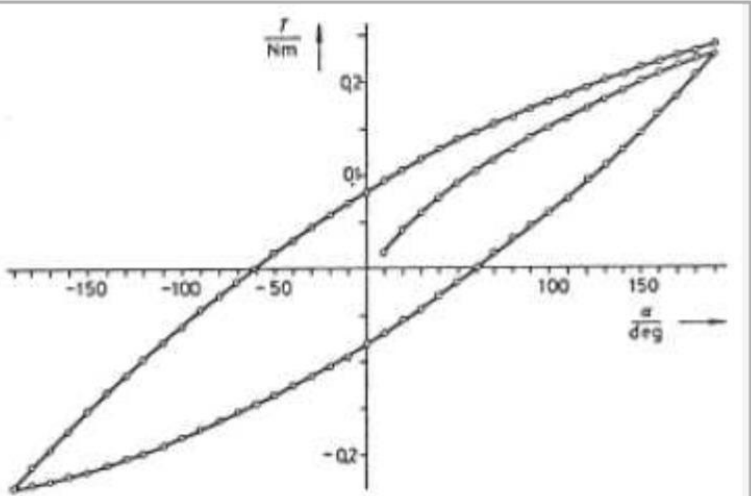


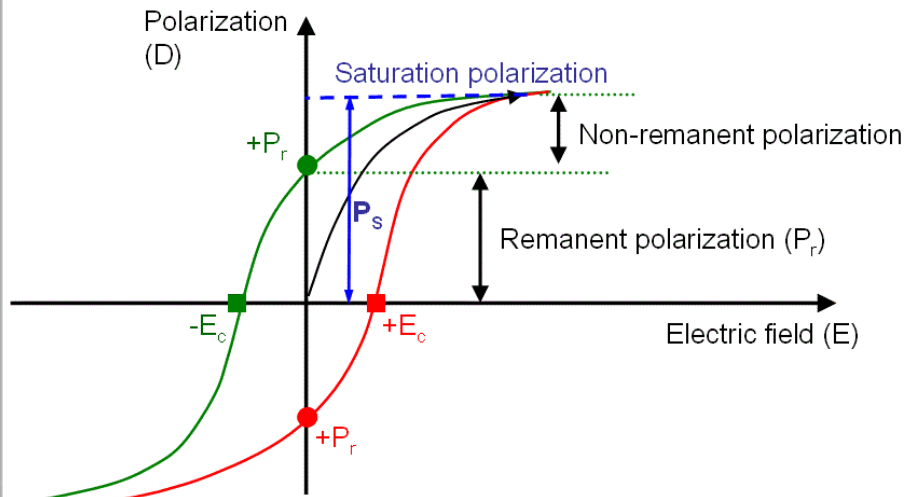
Fig. 3: Mechanical hysteresis curve for the torsion of a copper rod of 2 mm diameter and 0.5 m long.

Mechanical hysteresis

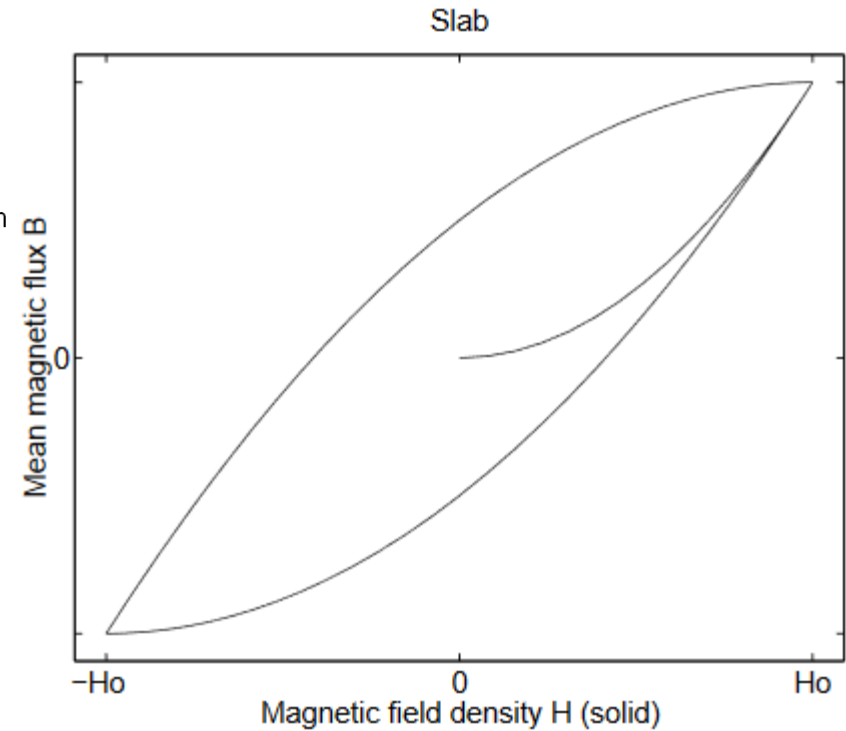


Fig. 1: Experimental set-up for measuring the hysteresis of metal bars in torsion.

Magnetic hysteresis,
adsorption hysteresis,
optical hysteresis,
electron beam hysteresis,
economic hysteresis, etc.



Ferroelectric hysteresis



Superconducting hysteresis

Hysteresis transducer (HT)

an input $u(t)$

an output $f(t)$.

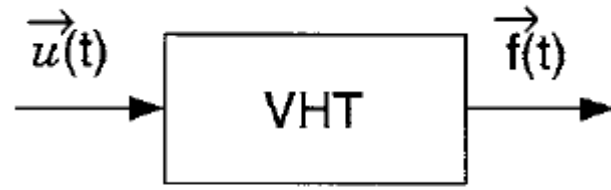
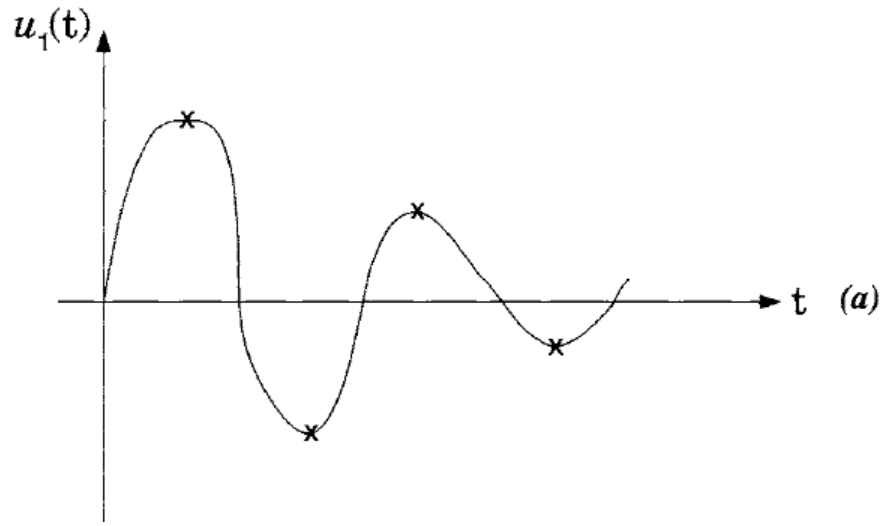


FIGURE 12



Multibranch nonlinearity

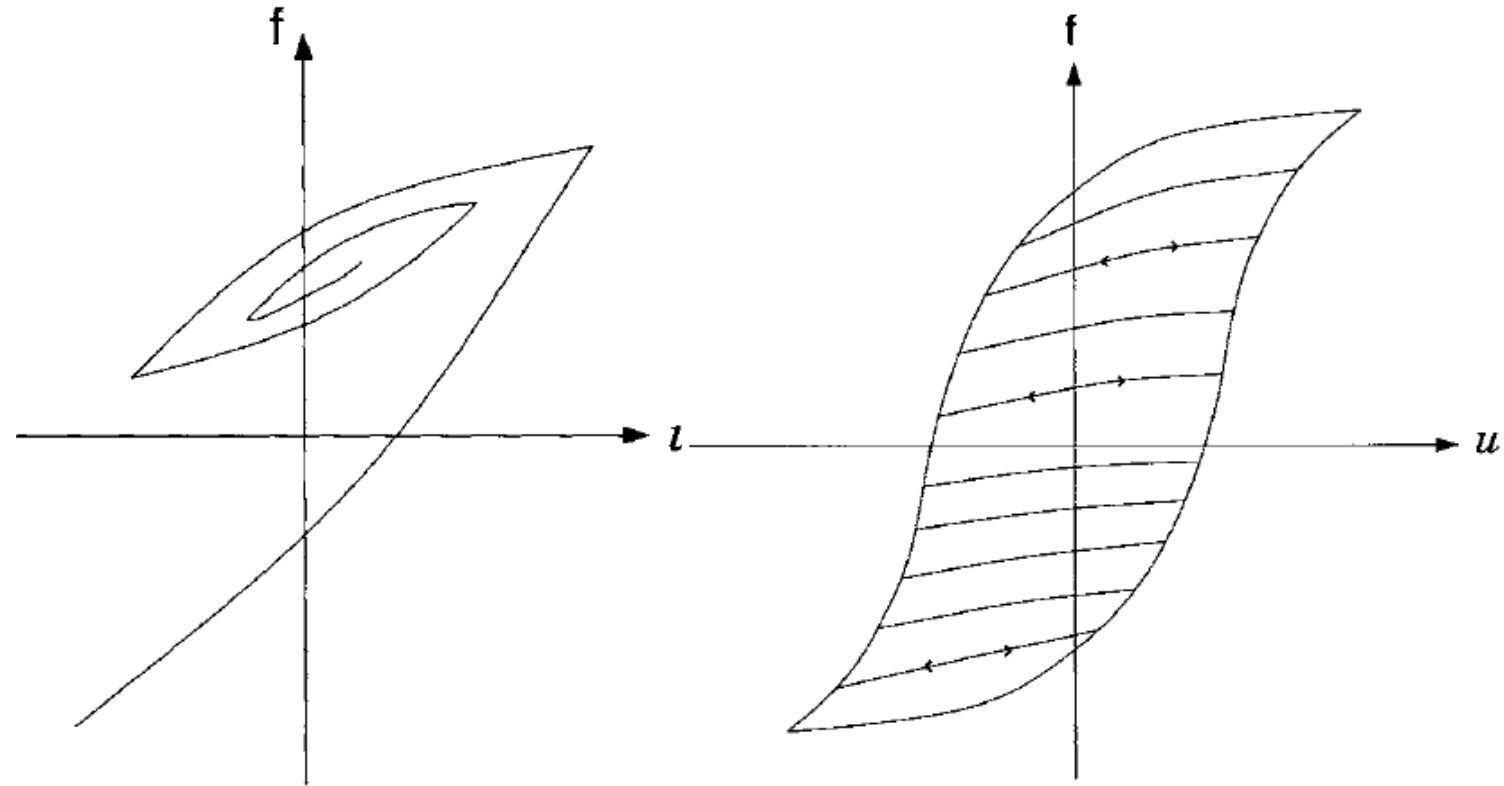


FIGURE 2

FIGURE 6

History dependent branching constitutes the essence of hysteresis

Mathematical description of the Preisach model

Preisach model is used for the mathematical description of hysteresis of various physical nature.

Hysteresis operators $\hat{\gamma}_{\alpha\beta}$

Assume $\alpha \geq \beta$

$$u > \alpha \quad \hat{\gamma}_{\alpha\beta} u(t) = +1$$

$$u < \beta \quad \hat{\gamma}_{\alpha\beta} u(t) = -1,$$

Numbers α and β correspond to "up" and "down" switching values of input.

Outputs of the above elementary hysteresis operators assume only two values, -1 and +1

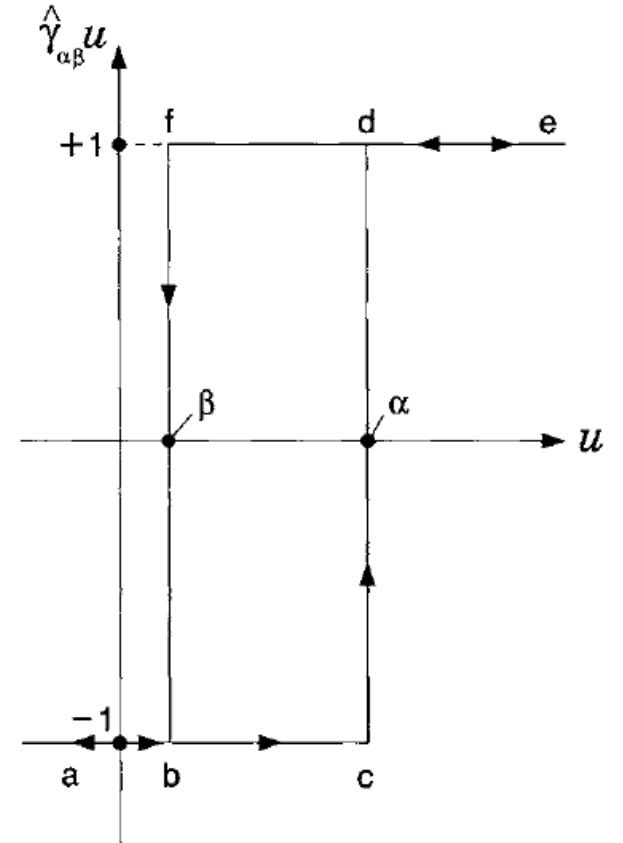


FIGURE 1.1

Mathematical description of the Preisach model

$$f(t) = \hat{\Gamma}u(t) = \iint_{\alpha \geq \beta} \mu(\alpha, \beta) \hat{\gamma}_{\alpha\beta} u(t) d\alpha d\beta. \quad (1.1)$$

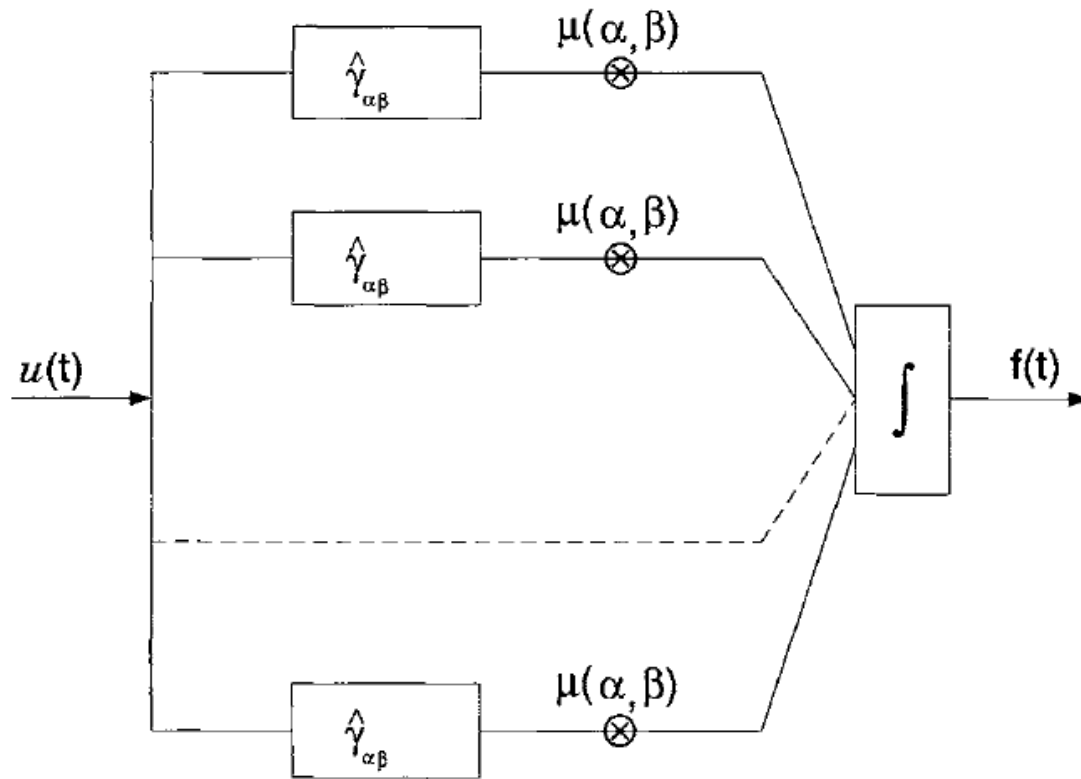


FIGURE 1.2

the Preisach model is constructed as a superposition of simplest hysteresis operators $\hat{\gamma}_{\alpha\beta}$

Two critical questions

1. How does the Preisach model work? In other words, how does this model detect local input extrema, accumulate them and choose the appropriate branches of hysteresis nonlinearity according to the accumulated histories?
2. What experimental data are needed for the determination of the Preisach function, $\mu(\alpha, \beta)$, for a given hysteresis transducer?

Geometric interpretation

One-to-one correspondence between operators $\hat{\gamma}_{\alpha\beta}$ and points (α, β) of the half-plane $\alpha \geq \beta$.

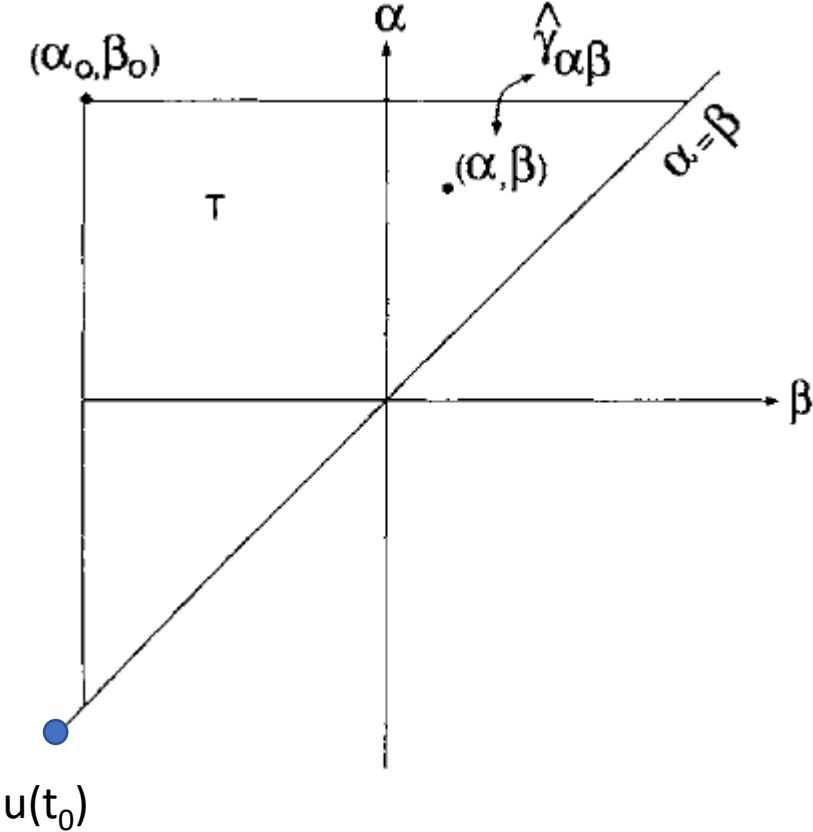


FIGURE 1.5

The weight function $\mu(\alpha, \beta)$ is equal to zero outside the triangle T.

1. At initial instant t_0 , assume the input $u(t_0) < \beta_0$, then outputs of all operator $\hat{\gamma}_{\alpha\beta}$ are equal to -1, the state of "negative saturation"

Geometric interpretation

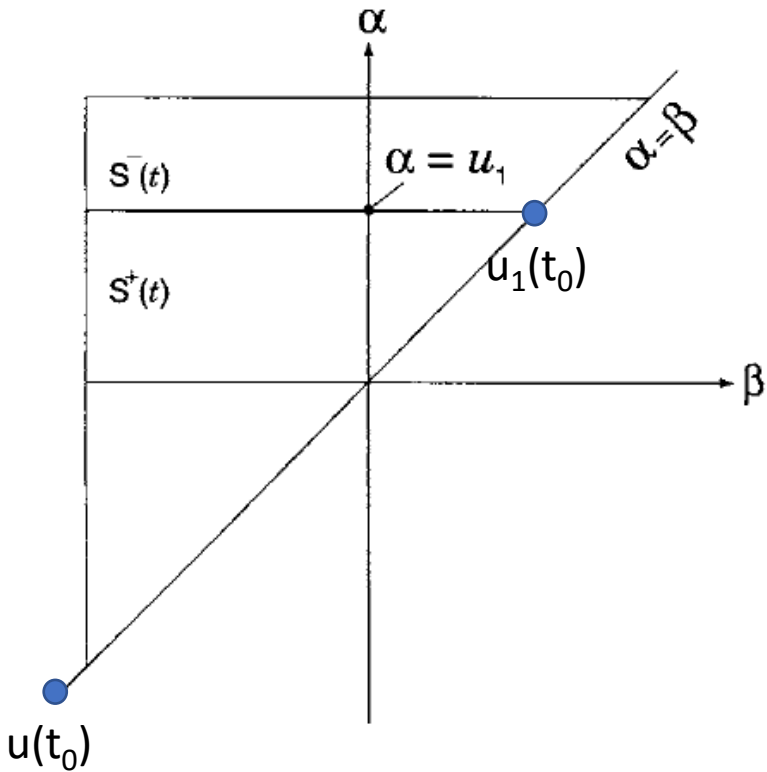


FIGURE 1.7

The weight function $\mu(\alpha, \beta)$ is equal to zero outside the triangle T. $\alpha \geq \beta$

1. At initial instant t_0 , assume the input $u(t_0) < \beta_0$, then outputs of all operator $\hat{\gamma}_{\alpha\beta}$ are equal to -1, the state of "negative saturation"
2. the input is monotonically increased, reach $u_1(t_1)$, all operator $\hat{\gamma}_{\alpha\beta}$ with $\alpha < u_1$ are being turned into +1, leading to the subdivision of the triangle T into two sets: $S^+(t)$ and $S^-(t)$

Geometric interpretation

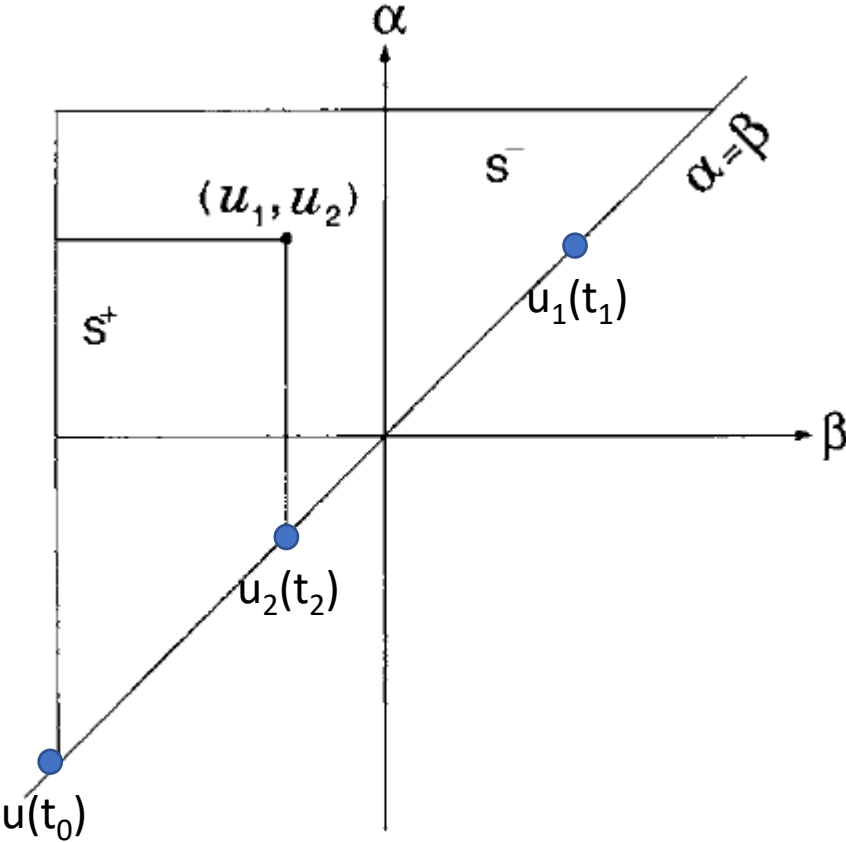


FIGURE 1.9

The weight function $\mu(\alpha, \beta)$ is equal to zero outside the triangle T.

1. At initial instant t_0 , assume the input $u(t_0) < \beta_0$, then outputs of all operator $\hat{\gamma}_{\alpha\beta}$ are equal to -1, the state of "negative saturation"
2. the input is monotonically increased, until reach $u_1(t_1)$, all operator $\hat{\gamma}_{\alpha\beta}$ with $\alpha < u_1$ are being turned into +1, leading to the subdivision of the triangle T into two sets: $S^+(t)$ and $S^-(t)$
3. the input is monotonically decreased, until reach $u_2(t_2)$, all operator $\hat{\gamma}_{\alpha\beta}$ with $\beta > u_2$ are being turned into -1

Geometric interpretation

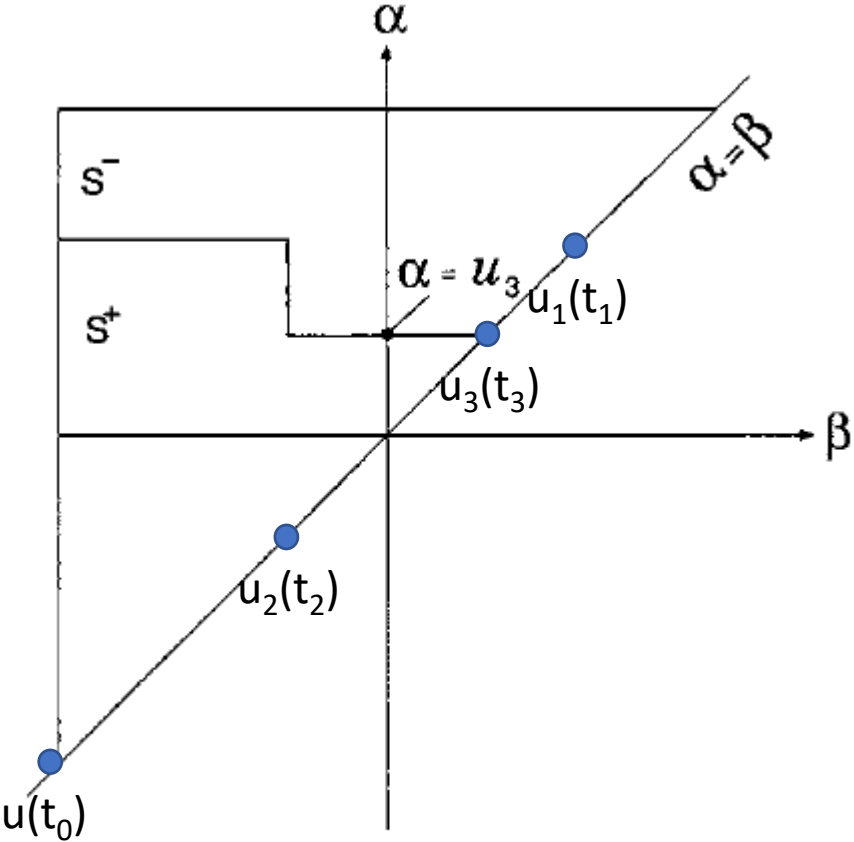


FIGURE 1.10

The weight function $\mu(\alpha, \beta)$ is equal to zero outside the triangle T.

1. At initial instant t_0 , assume the input $u(t_0) < \beta_0$, then outputs of all operator $\hat{\gamma}_{\alpha\beta}$ are equal to -1, the state of "negative saturation"
2. the input is monotonically increased, until it reaches $u_1(t_1)$, all operator $\hat{\gamma}_{\alpha\beta}$ with $\alpha < u_1$ are being turned into +1, leading to the subdivision of the triangle T into two sets: $S^+(t)$ and $S^-(t)$
3. the input is monotonically decreased, until it reaches $u_2(t_2)$, all operator $\hat{\gamma}_{\alpha\beta}$ with $\beta > u_2$ are being turned into -1
4. the input is increased again, until it reaches $u_3(t_3)$

Geometric interpretation

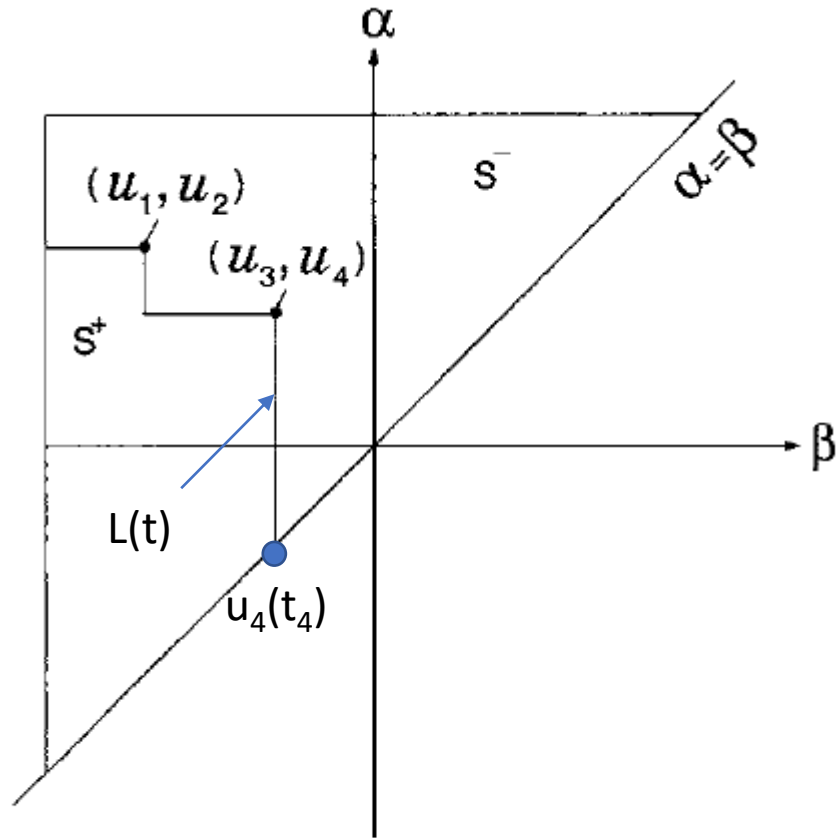


FIGURE 1.11

The weight function $\mu(\alpha, \beta)$ is equal to zero outside the triangle T.

1. At initial instant t_0 , assume the input $u(t_0) < \beta_0$, then outputs of all operator $\hat{\gamma}_{\alpha\beta}$ are equal to -1, the state of "negative saturation"
2. the input is monotonically increased, until it reaches $u_1(t_1)$, all operator $\hat{\gamma}_{\alpha\beta}$ with $\alpha < u_1$ are being turned into +1, leading to the subdivision of the triangle T into two sets: $S^+(t)$ and $S^-(t)$
3. the input is monotonically decreased, until it reaches $u_2(t_2)$, all operator $\hat{\gamma}_{\alpha\beta}$ with $\beta > u_2$ are being turned into -1
4. the input is increased again, until it reaches $u_3(t_3)$
5. Decrease again, until reach u_4

As a result, two vertices of $L(t)$ are formed,

Geometric interpretation

$$f(t) = \widehat{\Gamma}u(t) = \iint_{\alpha \geq \beta} \mu(\alpha, \beta) \hat{\gamma}_{\alpha\beta} u(t) d\alpha d\beta. \quad (1.1)$$

Some generalized conclusion

1. At any instant of time, the triangle T is subdivided into two sets $S^+(t)$ and $S^-(t)$
2. The staircase line $L(t)$ is determined by local maxima and minima of input at previous instants of time.

Therefore, at any instant

$$f(t) = \widehat{\Gamma} \mu(t) = \iint_{S^+(t)} \mu(\alpha, \beta) \hat{\gamma}_{\alpha\beta} u(t) d\alpha d\beta + \iint_{S^-(t)} \mu(\alpha, \beta) \hat{\gamma}_{\alpha\beta} u(t) d\alpha d\beta. \quad (1.5)$$

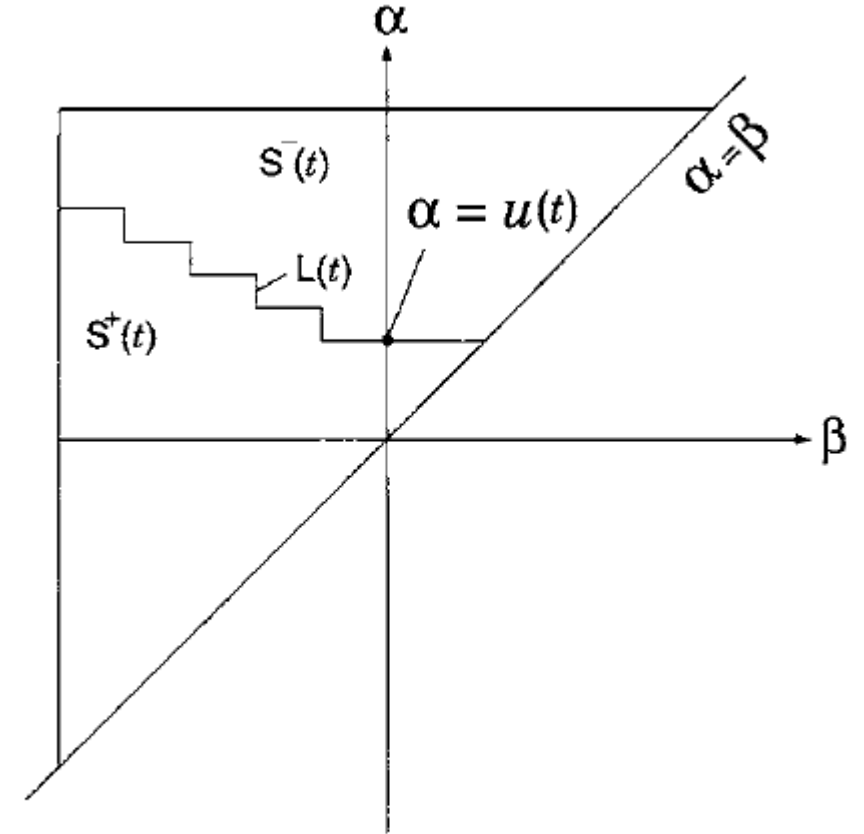


FIGURE 1.12

Geometric interpretation

$$f(t) = \widehat{\Gamma} \mu(t) = \iint_{S^+(t)} \mu(\alpha, \beta) \hat{\gamma}_{\alpha\beta} u(t) d\alpha d\beta + \iint_{S^-(t)} \mu(\alpha, \beta) \hat{\gamma}_{\alpha\beta} u(t) d\alpha d\beta. \quad (1.5)$$

$$\text{Since } \hat{\gamma}_{\alpha\beta} u(t) = +1, \quad \text{if } (\alpha, \beta) \in S^+(t) \quad (1.6)$$

$$\hat{\gamma}_{\alpha\beta} u(t) = -1, \quad \text{if } (\alpha, \beta) \in S^-(t), \quad (1.7)$$

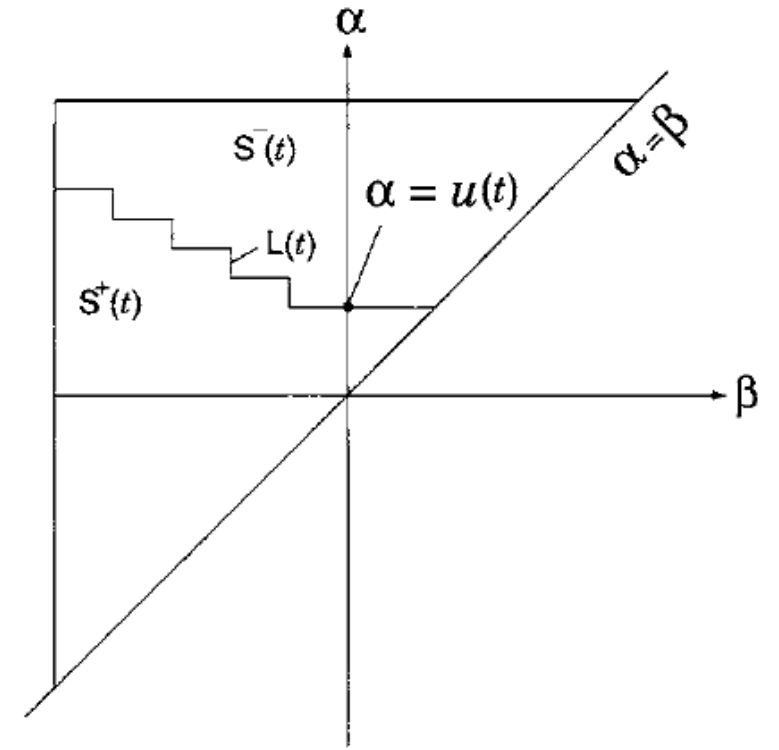


FIGURE 1.12

we find

$$f(t) = \iint_{S^+(t)} \mu(\alpha, \beta) d\alpha d\beta - \iint_{S^-(t)} \mu(\alpha, \beta) d\alpha d\beta. \quad (1.8)$$

it follows that an instantaneous value of output depends on a particular subdivision of the limiting triangle, T , into positive and negative sets $S^+(t)$ and $S^-(t)$, depending on the past extremum values of input.

The main properties of Preisach model

1. the output value, f^+ , in the state of positive saturation is equal to the minus output value, $-f^-$, in the state of negative saturation.

$$f^+ = \iint_T \mu(\alpha, \beta) d\alpha d\beta. \quad f^- = - \iint_T \mu(\alpha, \beta) d\alpha d\beta.$$

2. WIPING-OUT PROPERTY Each local input maximum wipes out the vertices of $L(t)$ whose α -coordinates are below this maximum, and each local minimum wipes out the vertices whose β -coordinates are above this minimum.

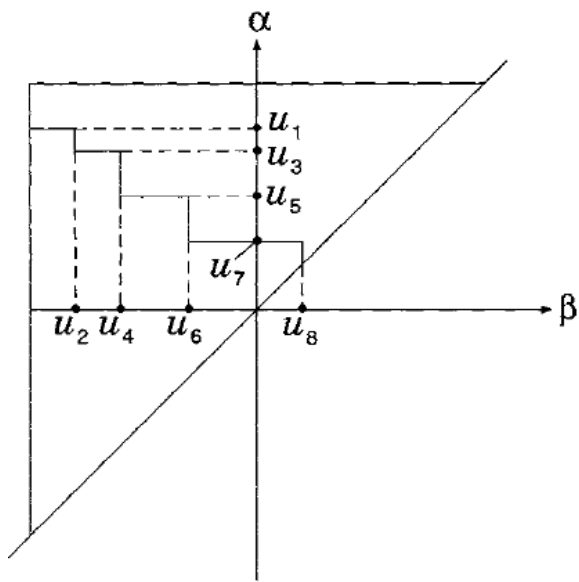


FIGURE 1.14

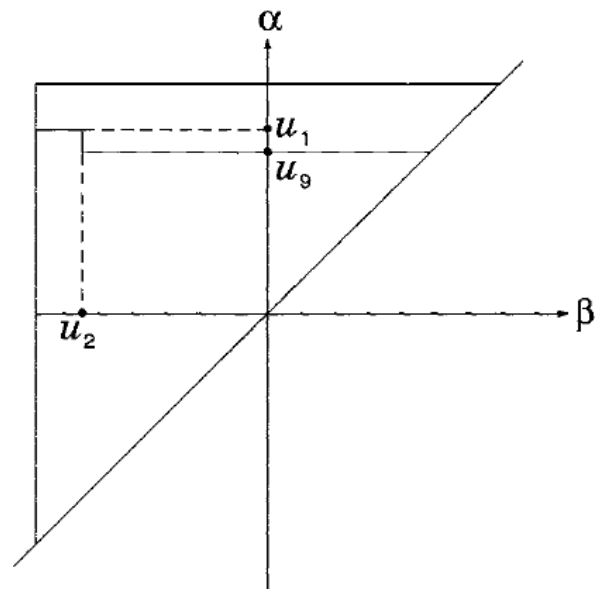


FIGURE 1.15

It means that any past history is wiped out by input oscillations of sufficiently large magnitude.

The main properties of Preisach model

3. CONGRUENCY PROPERTY All minor hysteresis loops corresponding to back-and-forth variations of inputs between the same two consecutive extremum values are congruent.

$u_1(t)$ and $u_2(t)$ be two inputs that may have different past histories

these inputs vary back and forth between the same two consecutive extremum values, u_+ and u_- .

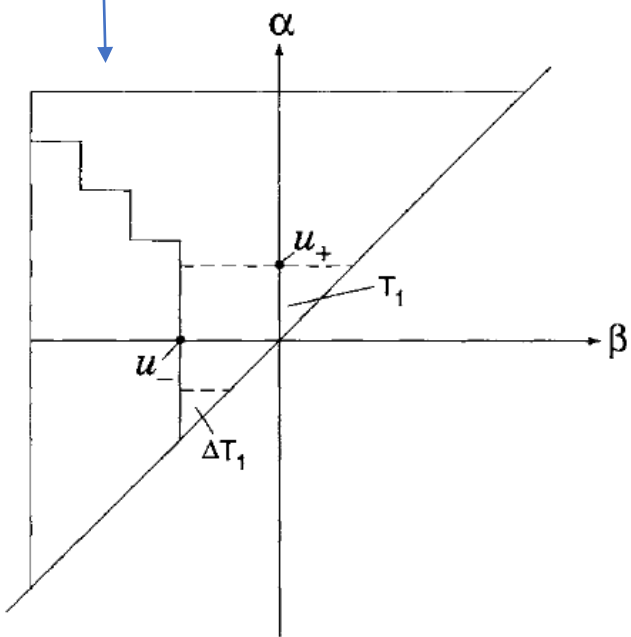


FIGURE 1.17

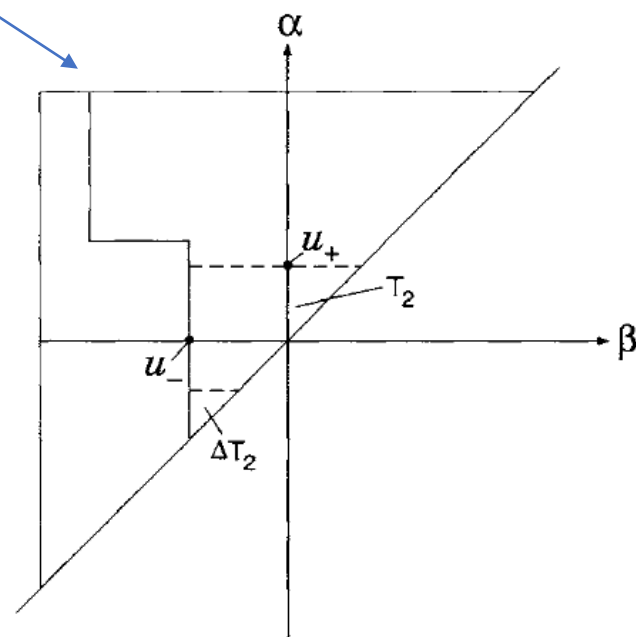


FIGURE 1.18

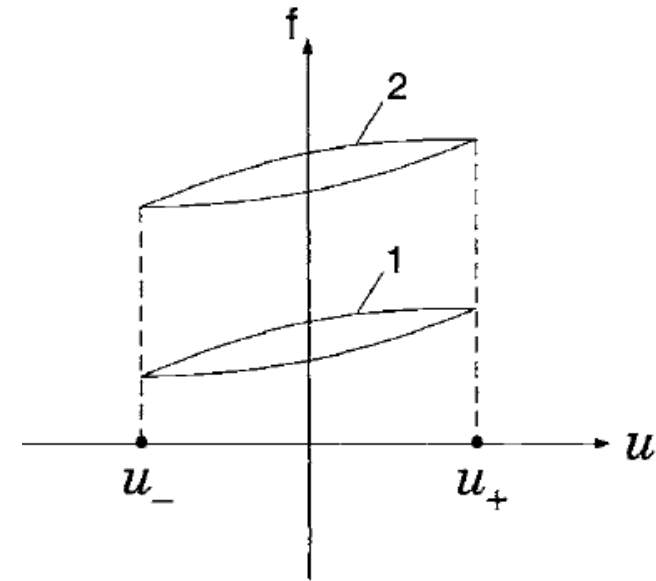


FIGURE 1.19

IDENTIFICATION PROBLEM FOR THE PREISACH MODEL

How do we find the weight function $\mu(\alpha, \beta)$?

1. Decrease the input $u(t)$ to the value that is less than β_0 , negative saturation
2. Monotonically increase $u(t)$ to α' , get ascending branch of a major loop, $f_{\alpha'}$
3. Reverse the input to get the first-order decreasing transition curve, $f_{\alpha'\beta'}$

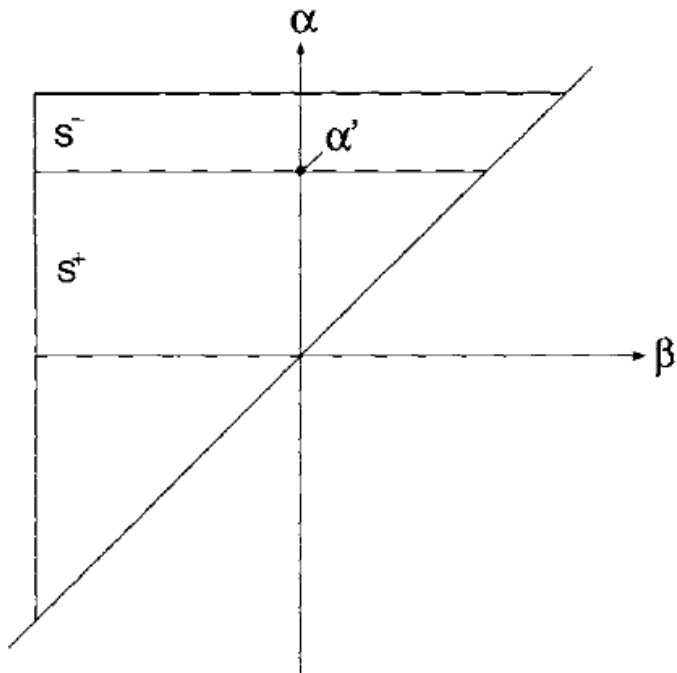


FIGURE 1.20

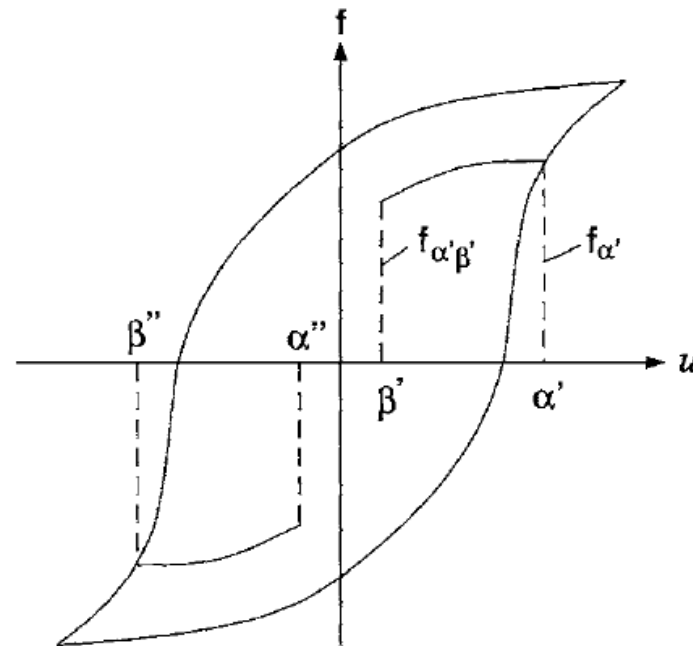


FIGURE 1.21

IDENTIFICATION PROBLEM FOR THE PREISACH MODEL

We define the function

$$F(\alpha', \beta') = \frac{1}{2}(f_{\alpha'} - f_{\alpha'\beta'}). \tag{1.24}$$

$$f_{\alpha'} = \iint_{S^+(t)} \mu(\alpha, \beta) d\alpha d\beta - \iint_{S^-(t)} \mu(\alpha, \beta) d\alpha d\beta$$

$$f_{\alpha'\beta'} = \iint_{S^+(t)-T} \mu(\alpha, \beta) d\alpha d\beta - \iint_{S^-(t)+T} \mu(\alpha, \beta) d\alpha d\beta$$

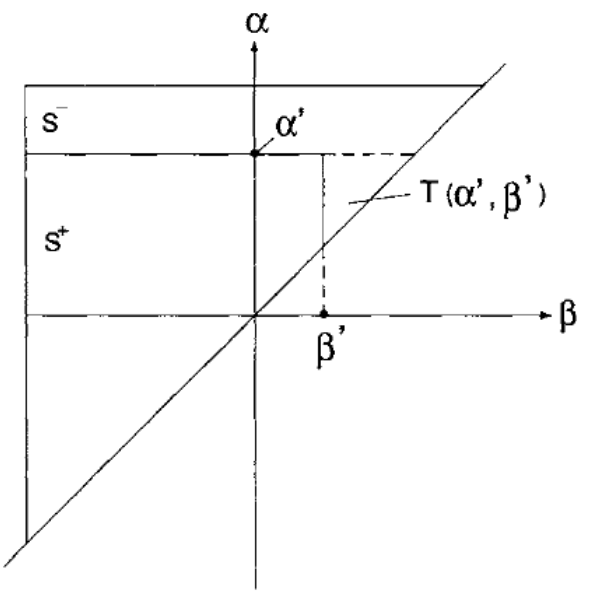


FIGURE 1.22

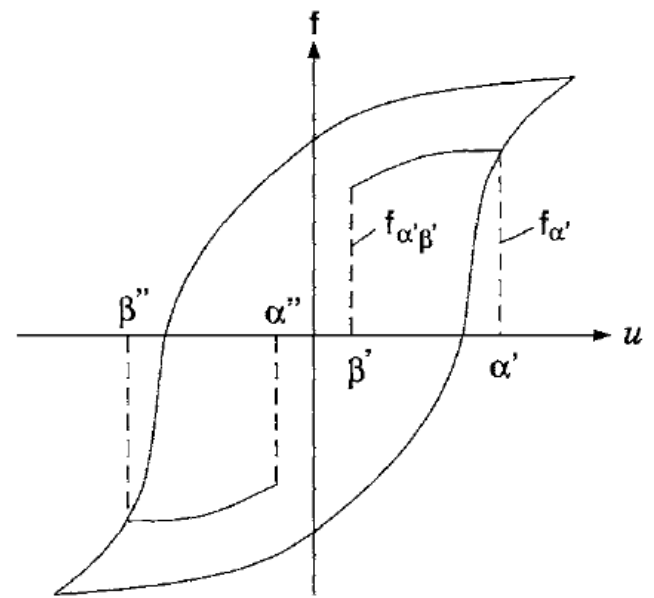
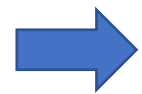


FIGURE 1.21



$$f_{\alpha'\beta'} - f_{\alpha'} = -2 \iint_{T(\alpha', \beta')} \mu(\alpha, \beta) d\alpha d\beta.$$

$$F(\alpha', \beta') = \iint_{T(\alpha', \beta')} \mu(\alpha, \beta) d\alpha d\beta.$$

$$F(\alpha', \beta') = \int_{\beta'}^{\alpha'} \left(\int_{\beta}^{\alpha'} \mu(\alpha, \beta) d\alpha \right) d\beta.$$

$$\mu(\alpha', \beta') = -\frac{\partial^2 F(\alpha', \beta')}{\partial \alpha' \partial \beta'}.$$

$$\mu(\alpha', \beta') = \frac{1}{2} \frac{\partial^2 f_{\alpha'\beta'}}{\partial \alpha' \partial \beta'}.$$

IDENTIFICATION PROBLEM FOR THE PREISACH MODEL

Consider the particular case when $\beta' = \beta_0$

$$f_{\alpha' \beta_0} = f^- \tag{1.32}$$

$$f^- - f_{\alpha'} = -2 \iint_{T(\alpha', \beta_0)} \mu(\alpha, \beta) d\alpha d\beta \tag{1.33}$$

For $\alpha' = \alpha_0$, we have

$$f_{\alpha_0} = f^+$$

$$f^- - f^+ = -2 \iint_T \mu(\alpha, \beta) d\alpha d\beta,$$

where $T = T(\alpha_0 \beta_0)$ is the limiting triangle.

Since major hysteresis loops are usually symmetric,

$$f^+ = -f^-.$$

$$f^- = - \iint_T \mu(\alpha, \beta) d\alpha d\beta.$$

This means that the Preisach model matches the output value in the state of negative saturation.

The Preisach function, $\mu(\alpha, \beta)$, has been found by using the first-order transition curves.

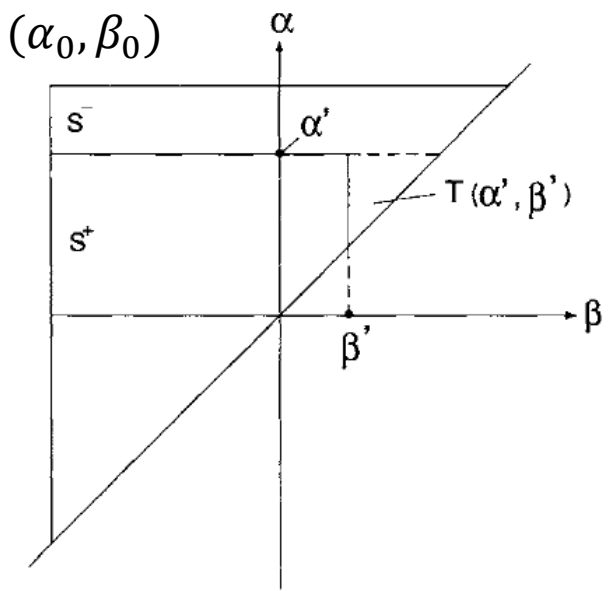


FIGURE 1.22

THANK YOU!
Any questions?